

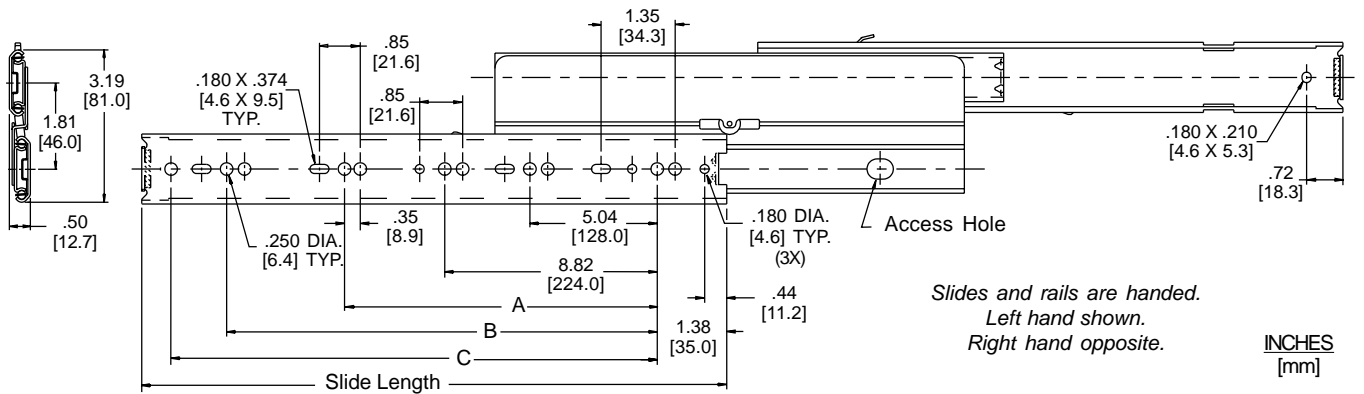

MODELS 4032, 4033 +Cam
4034, 4035 DRAWER
 ADJUST

APPLICATIONS: File drawers in desks, credenzas, and lateral files. Also store fixtures, hotel or institutional furniture. Vertical drawer adjustment with rail cam. **This product is covered by U.S. and various foreign patents issued and/or pending.**

32mm Hole Pattern
 Full Extension Heavy Duty Slide
 100 to 150 lb. [45 to 68 kg.] Capacity**

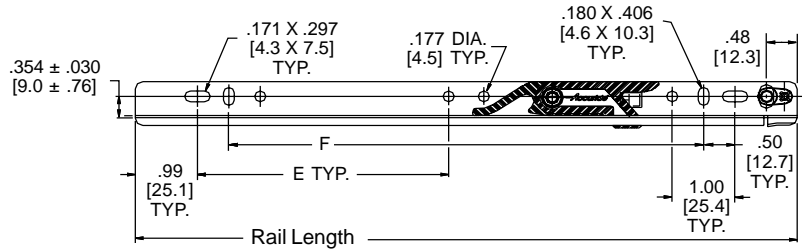
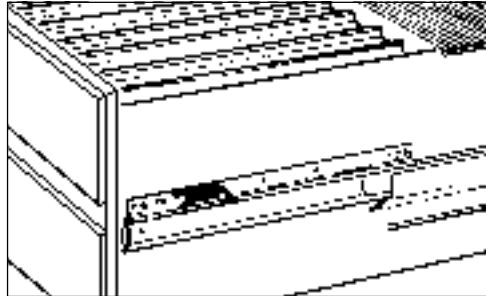

- Finish** Bright electro-zinc (C) or black zinc* (CB) plating available
- Length** 12" to 28" [300mm - 700mm]
- Height** 3.19" (3.79" including rail) [81.0mm (96.3mm including rail)]
- Travel** See Chart
- Movement** See Chart
- Load** Models 4032/4034: 150 lb.** [68 kg.]
 Models 4033/4035: 100 lb.** [45 kg.]

- Sidespace** 1/2" +1/32", -0.0 (.50" +.03", -0.0) [12.7mm (+0.8mm, -0.0)]
- Hardware** Flathead 6mm Euro screws or #8 pan head screws
- Mounting** Side mount only; 32mm or traditional hole pattern
- Disconnect** Rail lift off (See Chart)
- Features** Progressive movement, positive stop, silenced in and out, handed, detent in

Part Number	Actual Length	Travel		A	B	C
		4032/4033	4034/4035			
403X-12	11.81 [300]	12.27 [312]	13.27 [337]			
403X-14	13.78 [350]	14.21 [361]	15.21 [386]			
403X-16	15.75 [400]	16.15 [410]	17.65 [448]	12.60 [320.0]		
403X-18	17.72 [450]	18.10 [460]	19.60 [498]	13.86 [352.0]		
403X-20	19.69 [500]	20.03 [509]	21.53 [547]	16.38 [416.0]		
403X-22	21.65 [550]	21.95 [558]	23.45 [596]	13.86 [352.0]	17.64 [448.0]	18.90 [480.0]
403X-24	23.62 [600]	24.39 [620]	25.39 [645]	13.86 [352.0]	18.90 [480.0]	
403X-26	25.59 [650]	26.33 [669]	27.33 [694]	13.86 [352.0]	21.42 [544.0]	
403X-28	27.56 [700]	28.27 [718]	29.27 [743]	13.86 [352.0]	21.42 [544.0]	23.94 [608.0]

"X" = 2, 3, 4, 5

* Minimum order quantities may apply.

Model	Travel	Ball Bearings	Max. Drawer Width	Previous Model
4032	Full	Steel	27" [686mm]	437, 4025
4033	Full	Polymer	18" [450mm]	4037
4034	Over	Steel	24" [600mm]	417, 432, 4005
4035	Over	Polymer	18" [450mm]	4017

Rail Part Numbers	Fits Slide Length	Rail Length	E	F
7156-1214-XL	12" - 14"	10.54	4.00	7.56
7156-1214-XR	[300 - 350]	[267.7]	[101.6]	[192.0]
7156-1518-XL	15" - 18"	13.06	4.00	10.08
7156-1518-XR	[381 - 450]	[331.7]	[101.6]	[256.0]
7156-1921-XL	19" - 21"	16.84	4.00	13.86
7156-1921-XR	[483 - 533]	[427.7]	[101.6]	[352.0]
7156-2225-XL	22" - 25"	20.62	7.00	17.64
7156-2225-XR	[550 - 635]	[523.8]	[177.8]	[448.1]
7156-2628-XL	26" - 28"	24.40	7.00	21.42
7156-2628-XR	[650 - 700]	[619.8]	[177.8]	[544.1]

"X" = "C" for zinc finish; or "B" for black finish

** Models 4032/4034: 18" slide cycled 75,000 times.
 Models 4033/4035: 18" slide cycled 50,000 times.

Installation Instructions

Conventional Mounting

Cabinet Member Installation

1. Mark a horizontal line in the cabinet sidewall 1-1/2" (11/16" min.) up from the cabinet floor to the center line of the cabinet member. Mark a point on the line 2-3/8" in from the cabinet front. This will position the slide flush with the cabinet opening. For inset drawers, add the drawer front thickness to this dimension. See Figure 1.
2. Measure the distance between the front and rear horizontal slots on the slide. Mark this measurement on the horizontal line beginning at the first mark.
3. Make a pilot hole on each mark, either with an awl or 1/8" drill. Install #8 screws through the front and rear horizontal slots.

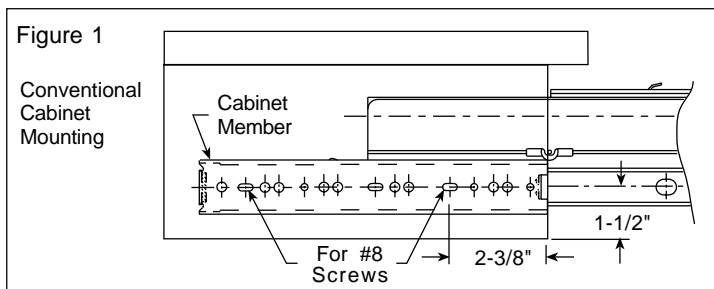

Rail Installation

1. Mark a horizontal line on the drawer side 2-27/32" above the center line of the cabinet member. See Figure 3.
2. Mark a point on this line 5/8" back from the drawer front. Install #8 screw through the cam adjuster and through a slot at the rear. See Figure 3.

NOTE: The cam screw must install on the same center line as the remaining rail mounting screws. This eliminates additional measuring and marking.

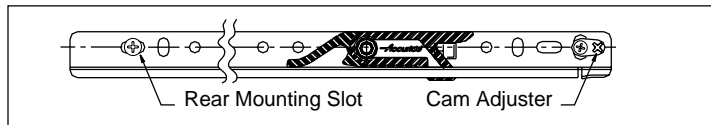

3. Connect the drawer to the extended slide members by lowering the drawer onto the slides so the rail lock arm rests on top of the slide members approximately 1" from the front. Pull both slides forward until the rail latch locks securely into each slide.

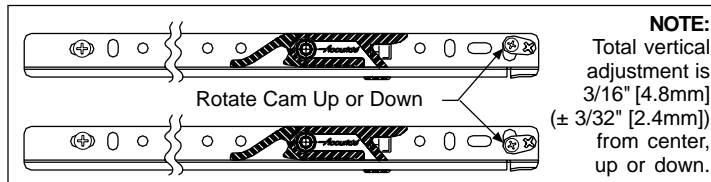

4. Rotate the cam with a Phillips or Pozi screwdriver to vertically position the drawer in relation to the cabinet.



5. **IMPORTANT:** After all adjustments are made, secure rail with additional mounting screws.

32mm System Mounting

Cabinet Member Installation

1. Install an M-6 euro screw through the second hole from the front of the slide and into a 6mm hole located 37mm in from the front of the cabinet. Select a rear mounting hole on one of the 32mm multiples provided and install screws. See Figure 2.

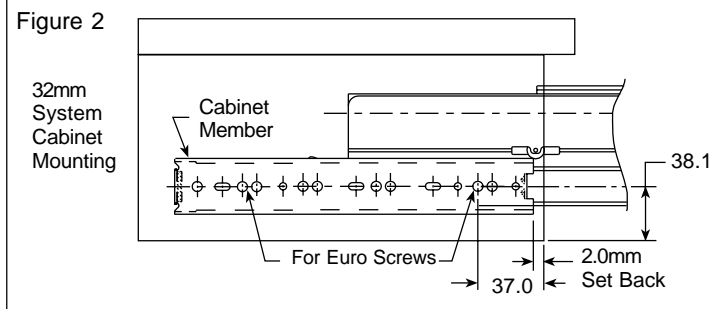

Rail Installation

1. Mark a horizontal line on the drawer side 72.4mm above the slide center line. See Figure 3.
2. Mark a point on this line 15.9mm back from the drawer front. Complete rail installation by following steps 3 through 5 above.

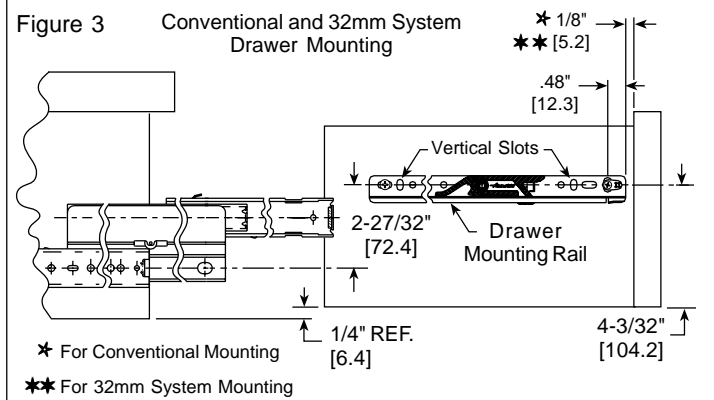

Slide/Rail Ordering Instructions

Complete your slide order for models 4032, 4033, 4034, 4035 by specifying the total slides required, slide finish, slide model, slide length, and optional polybag packaging.

Example: 10 Each C 4034 -12 D

Complete your rail order by specifying quantity, rail part number, rail finish ("C" for zinc; "B" for black) and hand ("L" for left hand; "R" for right hand).

Example: 10 Each 7156-1214-CL (zinc/left hand)
10 Each 7156-1214-BR (black/right hand)

Specifications

Slide members and ball retainers: Cold rolled steel
Ball bearings: Models 4032 & 4034: Carburized steel
Models 4033 & 4035: Acetal polymer

Note: Specifications, materials, prices, terms, and delivery are subject to change without notice.

Packaging Information

Distributor (D) Pack: Polybag includes one pair of slides, rails and screws. All lengths packaged 5 pair per box.

Bulk (P) Pack: Slides and rails are packed in separate boxes. Lengths 12"-18" - 20 each/box. Lengths 20"-28" - 10 each/box.

X-Pack (X): Slides, rails and screws are packed in one box. All models available. All lengths packaged 5 pair per box.

Copyright © 2002 Accuride International Inc. Printed in U.S.A. 3700-9082(9309)-MK538-R9-0603

Accuride

ACCURIDE INTERNATIONAL INC.

12311 Shoemaker Avenue
Santa Fe Springs, CA 90670

TEL (562) 903-0200

FAX (562) 903-0208

www accuride.com

Manufacturing, Engineering, and Sales
United States • Germany • Japan • Mexico • United Kingdom

Copyright © 2002 Accuride International Inc. Printed in U.S.A. 3700-9309(9082)-MK039-R9-0603