

APPLICATIONS: For use in keyboard shelves for wood computer-specific furniture. Not intended for lateral file• drawer applications. Use for side mount only. **This product is covered by U.S. (5,980,007) and various foreign patents issued and/or pending.**

32mm System Box Drawer Slide
Detent In and Out
Vertical Drawer Adjustment
Optional Face Frame Brackets

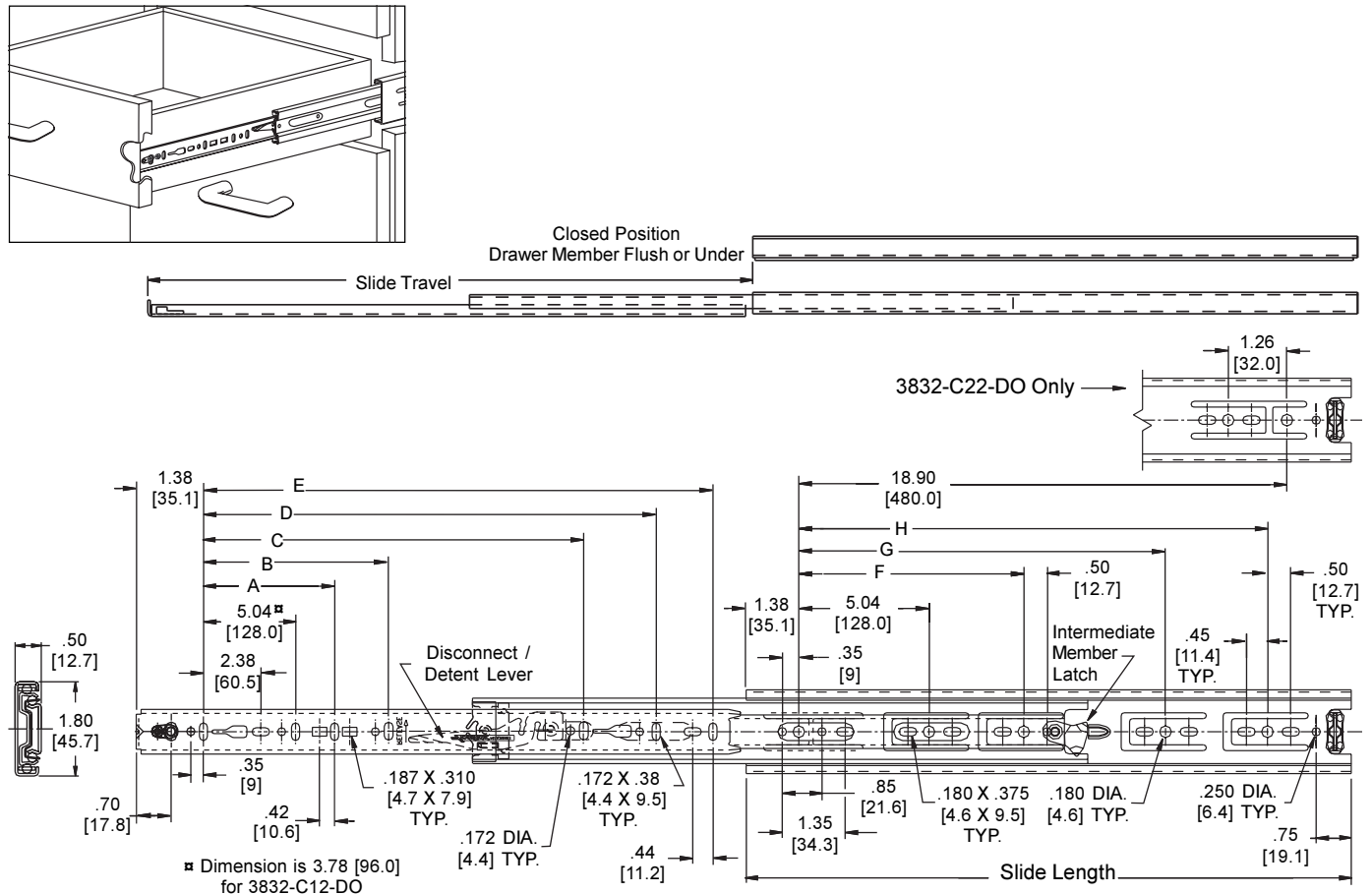

- Finish** Clear electroplate (C), black electroplate ♦ (CB) finish
- Length** 12" - 28" [300mm - 700mm]
- Side Space** .50" +0.062 / -0.0 [12.7mm +1.6 / -0.0]
- Travel** Full extension
- Height** 1.80" [45.7mm]
- Load** 100 lbs. per pair ■ [45.5 kg.] per pair
- Disconnect** Front, handed lever
- Mounting** Side, optional face frame brackets
- Hardware** Flat head 6mm Euro System screw or #8 pan head screw
- Ball Bearings** Steel
- Features** Detent open and closed; drawer member vertical cam adjustment; silenced open and closed.
- Load rating based on 18" slides mounted in a 16" wide drawer cycled 50,000 times.
- A lateral file drawer is wider than it is deep.
- ◆ Minimum order quantities may apply.

Part Number	Slide Length	Slide Travel	A	B	C	D	E	F	G	H
3832-C12-DO	11.81 [300]	12.00 [305]					9.52 [242]	8.82 [224]		
3832-C14-DO	13.78 [350]	14.00 [356]					11.50 [292]	8.82 [224]		
3832-C16-DO	15.75 [400]	16.00 [406]					13.47 [342]	8.82 [224]	12.60 [320]	
3832-C18-DO	17.72 [450]	18.00 [457]			12.60 [320]		15.43 [392]		13.86 [352]	
3832-C20-DO	19.69 [500]	20.00 [508]			12.60 [320]		17.40 [442]		16.38 [416]	
3832-C22-DO	21.65 [550]	22.00 [559]			12.60 [320]	16.38 [416]	19.37 [492]		13.86 [352]	
3832-C24-DO	23.62 [600]	24.00 [610]	8.82 [224]		16.38 [416]		21.34 [542]	8.82 [224]	13.86 [352]	18.90 [480]
3832-C26-DO	25.59 [650]	26.00 [660]	8.82 [224]		16.38 [416]	21.42 [554]	23.31 [592]	8.82 [224]	13.86 [352]	21.42 [554]
3832-C28-DO	27.56 [700]	28.00 [711]	8.82 [224]	11.34 [288]	16.38 [416]	21.42 [554]	25.28 [642]	8.82 [224]		21.42 [554]

Installation Instructions

Install Cabinet Member

1. Separate slide members by simultaneously lifting up the left hand disconnect lever and pushing down the right hand lever.
2. Install cabinet (large) member first. For applications with an overlay drawer front, refer to Figure 1 for conventional mounting and Figure 2 for 32mm System mounting. For applications with an inset drawer front, set the slide back the thickness of the drawer front plus 1/8" [3.2mm].

Install Drawer Member

3. Install the drawer member with a screw through the cam adjuster and through a hole or slot at the rear.

NOTE: Cam **must** install on same center line as drawer member.

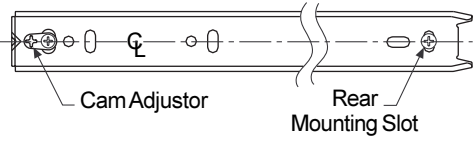

Cam Adjuster Rear Mounting Slot

NOTE: The cam is designed for use with the standard Accuride truss head screw. If using other screw, ensure screw head height does not exceed 1/16" [1.6mm] since it may cause interference.

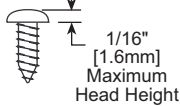

1/16" [1.6mm] Maximum Head Height

Accuride part number 2410-3218-CE

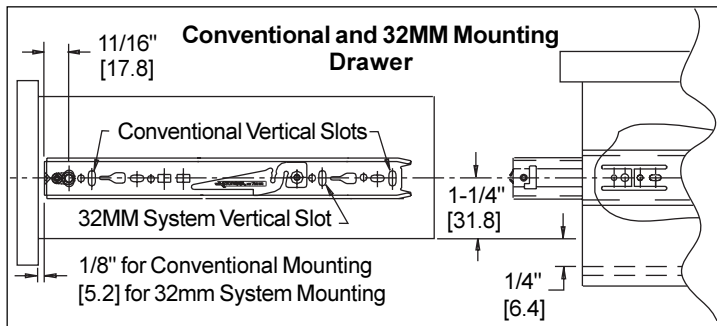
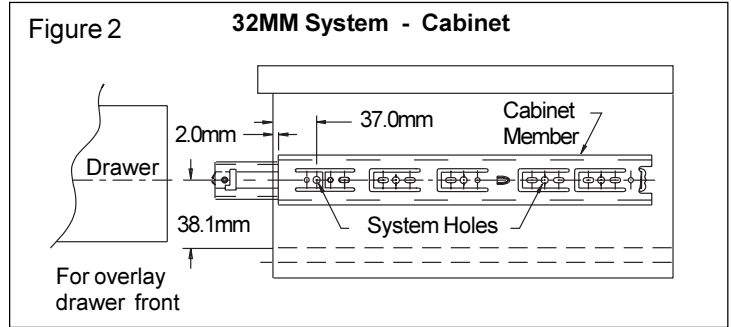
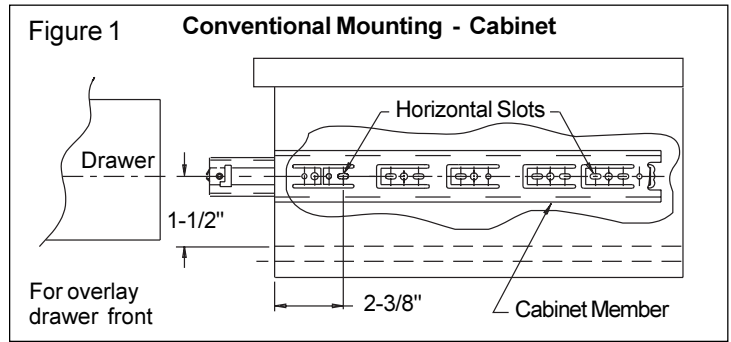

4. Make sure the ball bearing retainers in the cabinet side are fully forward. Install drawer into cabinet. Close the drawer.
5. Open the drawer and rotate the cam with a Phillips or Pozi screwdriver to vertically position the drawer in relation to the cabinet.

NOTE: Total vertical adjustment is 1/8" [3.2mm] ±1/16" [1.6mm] from center, up and down.

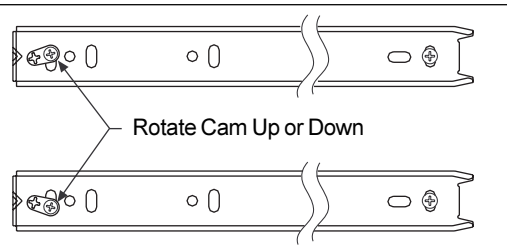

Rotate Cam Up or Down

6. Install additional set screws to secure.

NOTE: Install drawer pulls or knobs **after** set screws are in place.

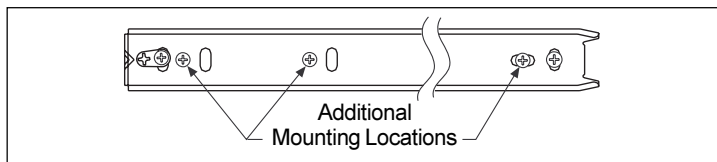

Slide Ordering Instructions

Complete your slide order for Accuride models 3832-DO by specifying the following:

10 Pair C 3832 -C18 -DO D

Total Required Slides _____

Slide Finish _____

Slide Model _____

Slide Length _____

Detent Out Feature _____

Polybag Packaging _____

Optional Face Frame Brackets

Face frame brackets are ordered as a kit or in bulk. Brackets are available in clear zinc finish only. Mounting screws are not included.

To order **kits**, specify part number 4180-0322-XE. Each kit contains:

- 2 front brackets,
 - 2 rear brackets, and
 - installation instructions.
- Order 1 kit per pair of slides.

For **bulk**, order 2 front brackets (P/N 4180-0516-CE) and 2 rear brackets (P/N 4080-0508-CE) per pair of slides.

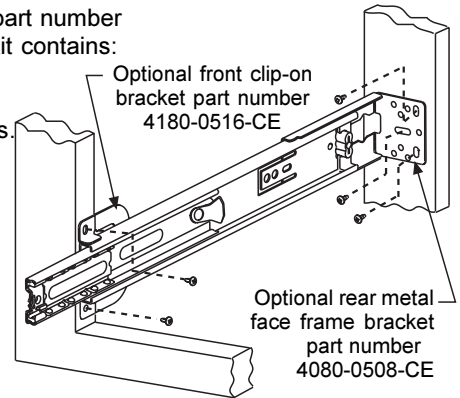

Packaging

Distributor (D) Pack: All lengths are packaged 10 pair per box. Polybag includes one pair of slides with mounting screws.

Bulk (P) Pack: All lengths are packaged 10 pair per box. Slides and screws are ordered and packaged separately.

Specifications

Slide members and ball retainers: Cold rolled steel
Ball bearings: Carburized steel

Note: Specifications, materials, prices, terms, and delivery are subject to change without notice.

Accuride

ACCURIDE INTERNATIONAL INC.

12311 Shoemaker Avenue
Santa Fe Springs, CA 90670
TEL (562) 903-0200
FAX (562) 903-0208
www.accuride.com

Manufacturing, Engineering, and Sales
United States • Germany • Japan • Mexico • United Kingdom