

APPLICATIONS: In-counter butcher blocks and cutting boards, typewriter and home personal computer shelves.

Lock-Out Slide
110 lb. [50 kg.] Capacity
Available in Lengths 16" to 22"
[406mm to 559mm]

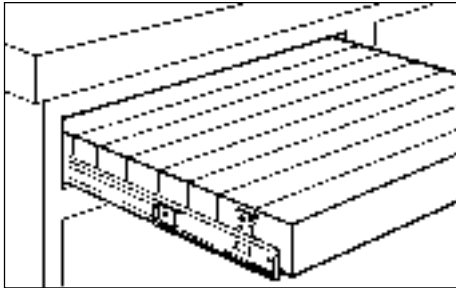

Front Lift-Out Bracket
Part Number 4010-0147-CE
(Unhanded, Zinc Finish)

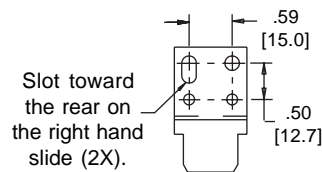

Rear Lift-Out Bracket
Part Number 4010-0148-CL
(Left Hand, Zinc Finish)
Part Number 4010-0149-CR
(Right Hand, Zinc Finish)

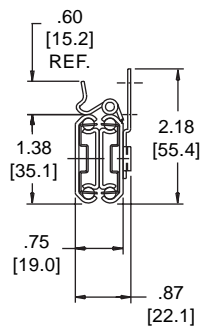
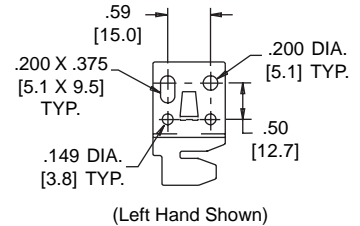

INCHES
[mm]

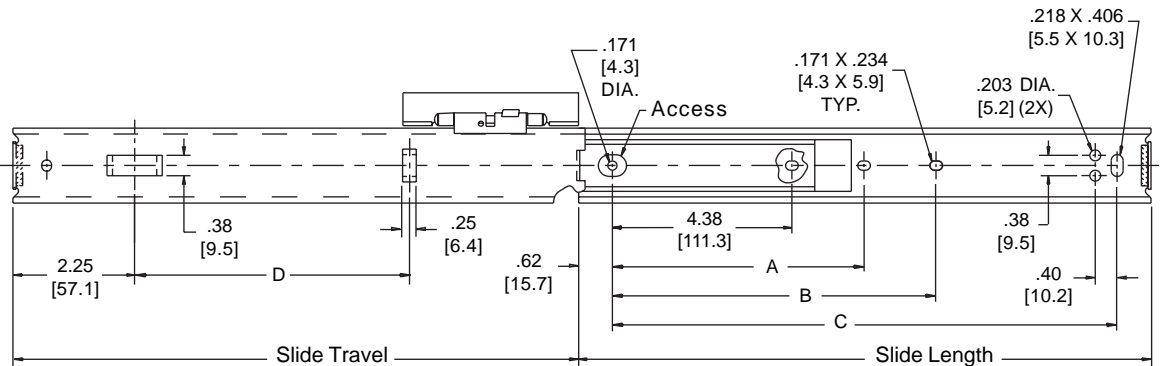

Finish Bright electro-zinc (C) or black zinc* (CB) plating available

Length 16", 18", 20", and 22"
[406.4mm, 457.2mm, 508.0mm, 558.8mm]

Height Slide: 1.38" [35.1mm]
Slide with bracket: 2.18" [55.4mm]

Travel Slide length less 0.12" [3.1mm]

Load 110 lbs.** [50 kg.]

Sidespace .87" [22.1mm]

Mounting Bracket and pocket

Disconnect Bracket and pocket

Also Handed slide, lock-out in the extended position. Easily disconnects for removal and/or cleaning of work surface.

Part Number	Slide Length	Slide Travel	A	B	C	D
340-249	16.00 [406.4]	15.88 [403.4]		9.88 [251.0]	14.75 [374.7]	10.50 [266.7]
340-248	18.00 [457.2]	17.88 [454.2]	8.38 [212.9]	11.88 [301.8]	16.75 [425.5]	12.50 [317.5]
340-247	20.00 [508.0]	19.88 [505.0]	9.38 [238.3]	13.88 [352.6]	18.75 [476.3]	14.50 [368.3]
340-176	22.00 [558.8]	21.88 [555.8]	10.38 [263.7]	15.88 [403.4]	20.75 [527.1]	16.50 [419.1]

* Minimum order quantities may apply ** Load rating based on an 18" slide in an 18" wide drawer cycled 50,000 times.

Installation Instructions

1. Refer to Figure 1 for cabinet hole locations. Install cabinet members using #8 screws through horizontal slots. Members with pockets are shelf members. Be sure slides are parallel.
2. Refer to Figure 2 (and chart below) for front and rear mounting bracket hole locations. Install screw through vertical slots.

Part Number	Slide Length	"E" (Right Hand)	"F" (Left Hand)
340-249	16.00 [406.4]	13.00 [330.2]	12.40 [315.0]
340-248	18.00 [457.2]	15.00 [381.0]	14.40 [365.8]
340-247	20.00 [508.0]	17.00 [431.8]	16.40 [416.6]
340-176	22.00 [558.8]	19.00 [482.6]	18.40 [467.4]

3. Extend the slides fully forward. Slides should lock. Install shelf by lowering the rear brackets through the rear slide pockets. See Figure 3. Lower shelf until front brackets snap into slide lanced out pockets.
4. Close shelf fully to locate horizontal position of slide in cabinet. Open shelf to install remaining screws. Secure brackets after adjusting the shelf vertically.

NOTE: To remove the shelf, open fully to locked position. Lift shelf up and outward.

Ordering Procedure

Complete your slide order for Accuride Model 340 by specifying the following:

Total Slides Required _____ 100 Pair C 340 -176 D
 Slide Finish _____
 Slide Model _____
 Part Number for 22" Slide Length _____
 Optional Polybag Packaging _____

Packaging

Distributor (D) Pack: All lengths are packaged 5 pair per box. Polybag includes 2 slides, 2 front unhandled lift-out brackets, 1 left hand and 1 right hand lift-out brackets, and mounting screws.

Bulk Pack: All lengths are packaged 20 each per box. Slides are packed with left hand in one box and right hand in one box. Slides and lift-out brackets ordered and packaged separately.

Optional Brackets

Two front unhandled lift-out brackets, one left hand lift-out bracket, and one right hand lift-out bracket are required per pair of slides ordered. For bulk orders, specify as follows:

200 each 4010-0147-CE (Unhandled)
 100 each 4010-0148-CL (Left Hand)
 100 each 4010-0149-CR (Right Hand)

Total brackets required _____
 (For 100 pair slide order)

Bracket part numbers _____

For zinc finish order CE (unhandled), CL (left hand), CR (right hand)
 For black finish order BE (unhandled), BL (left hand), BR (right hand)

Specifications

Slide members: Cold rolled steel
 Ball retainers: Cold rolled steel
 Ball bearings: Carburized steel

Note: Specifications, materials, prices, terms, and delivery are subject to change without notice.

Figure 1

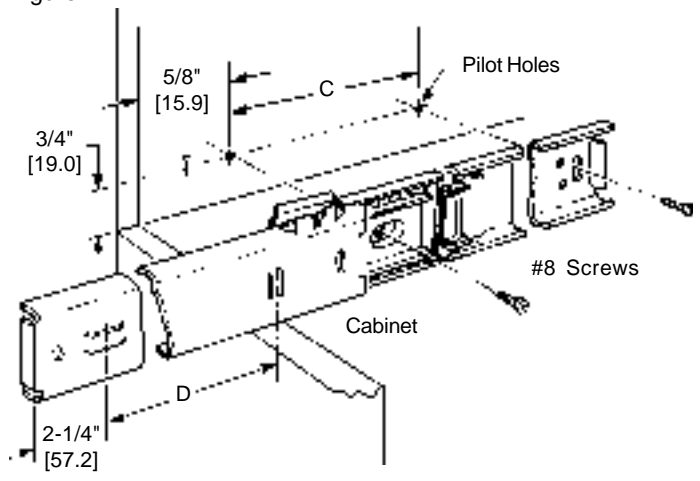

Figure 2

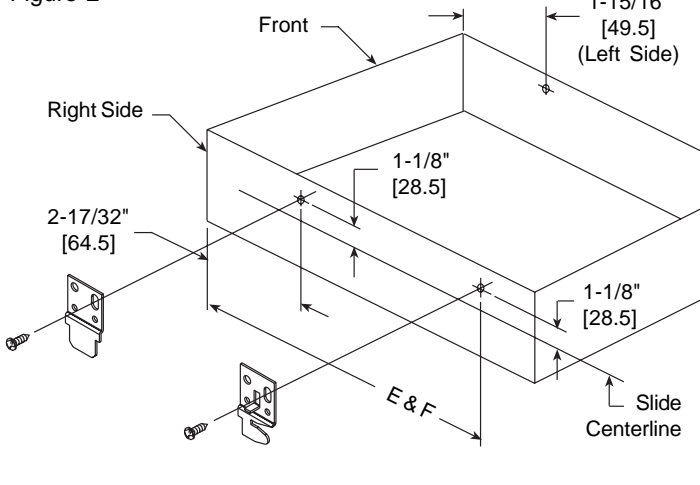
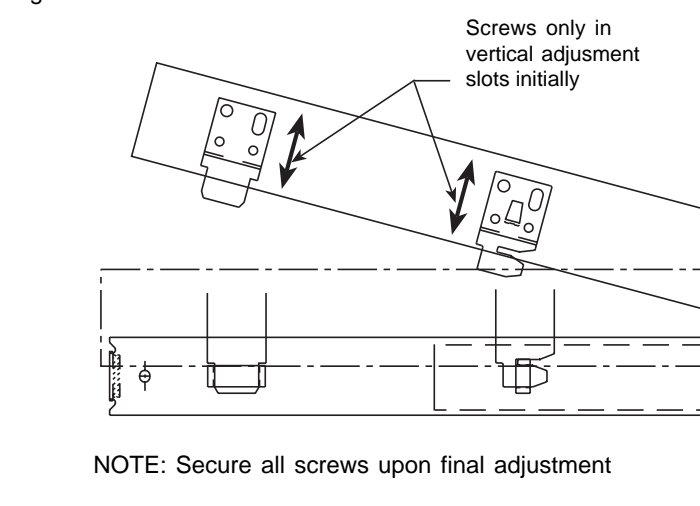

Figure 3



Accuride

ACCURIDE INTERNATIONAL INC.

12311 Shoemaker Avenue
 Santa Fe Springs, CA 90670

TEL (562) 903-0200

FAX (562) 903-0208

www.accuride.com

Manufacturing, Engineering, and Sales

United States • Germany • Japan • Mexico • United Kingdom