

APPLICATIONS: For use in small to medium cabinet, desk, kitchen, and store fixture drawers whenever a full extension, very low profile slide is required. **This product is covered by U.S. (6,254,209) and various foreign patents issued and/or pending.**

Very Low Profile
Full Extension Slide
Up to 75 lb. [34 kg.] Capacity **

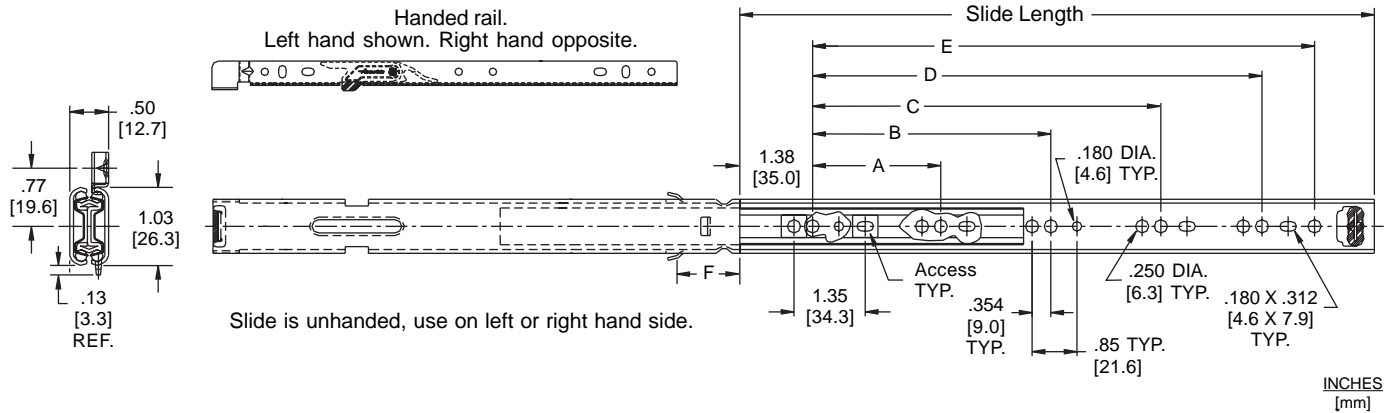
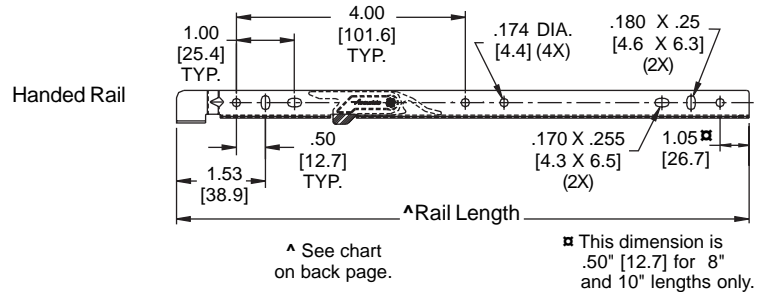
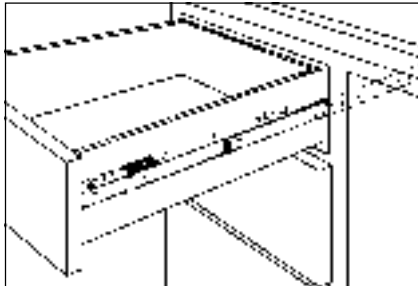

INCHES
[mm]

- Finish** Bright electro-zinc (C) and black zinc• (CB) plating available
- Length** Even lengths: 8" - 22"
Even lengths: [203mm - 559mm]
- Travel** Full extension
- Height** 1.16" (1.62" including rail)
[29.5mm (41.2mm including rail)]
- Load** Up to 65 lbs. [30 kg.]*
(KCMA - 75 lbs. [34 kg.]**) **
- Sidespace** .50" +.030 -.000 (1/2" +1/32 -.0)
- Mounting** Side, handed rail
- Hardware** #6 truss head screw or M-6 Euro screw or Accuride screw provided in D-pack (part number 2410-3218)
- Disconnect** Handed rail lift-off
- Movement** Steel ball bearings
- Features** Silenced positive stops in and out, traditional and 32mm hole pattern, hold-in detent. Vertical adjustment on drawer and horizontal adjustment in cabinet.
- Racking Notice** For assistance with special applications in which the drawer exceeds the recommended 16" [406mm] maximum width, contact Accuride Technical Support at (562) 903-0200.

Part Number	Slide Length	Slide Travel	A	B	C	D	E	F
2632-8	8.00 [203]	8.00 [203]	5.04 [128.0]					1.48 [37.6]
2632-10	10.00 [254]	10.00 [254]	5.04 [128.0]					3.48 [88.4]
2632-12	12.00 [305]	12.00 [305]	5.04 [128.0]	8.82 [224.0]				1.38 [35.1]
2632-14	14.00 [356]	14.00 [356]	5.04 [128.0]	8.82 [224.0]				3.38 [85.9]
2632-16	16.00 [407]	16.00 [407]	5.04 [128.0]	8.82 [224.0]	12.60 [320.0]			2.86 [72.6]
2632-18	18.00 [457]	18.00 [457]	5.04 [128.0]	8.82 [224.0]	13.86 [352.0]			4.86 [123.4]
2632-20	20.00 [508]	20.00 [508]	5.04 [128.0]	8.82 [224.0]	16.38 [416.0]			3.08 [78.2]
2632-22	22.00 [559]	22.00 [559]	5.04 [128.0]	8.82 [224.0]	13.86 [352.0]	17.64 [448.1]	18.90 [480.1]	5.08 [129.0]

- Minimum order quantities may apply.
- * 65 lb. load rating based on an 18" slide on a 16" wide drawer cycled 50,000 times.
- ** 75 lb. kitchen load rating based on a 22" slide on a 16" wide drawer extended 2/3 travel, cycled 25,000 times.

Mounting Instructions

Conventional Mounting

Cabinet Member Installation

1. Mark a horizontal line in the cabinet sidewall at least 25/32" up from the cabinet floor to clear the rail hook or at least 1" down from the top of the drawer side to clear the rail. Mark a point on the line 2-11/32" in from the cabinet front. This will position the slide flush with the cabinet opening. For inset drawers, add the drawer front thickness to the 2-11/32" dimension. See Figure 1.

NOTE: To access the additional mounting holes in the cabinet member of the slide, it is necessary to move the intermediate member to line up the access holes and the mounting hole.

2. Measure the distance between the front and rear horizontal slots on the slide. See Figure 1. Mark this measurement on the horizontal line beginning at the first mark.
3. Make a pilot hole on each of these marks, either with an awl or 1/8" drill. Install #6 truss head or special screw (provided in D-Pack) through the front and rear horizontal slots.

Rail Installation

1. Mark a horizontal line on the drawer side 25/32" above the slide center line. See Figure 2.
2. Mark a point on this line 1-21/32" back from the drawer front.
3. Measure the distance between the front and rear vertical slots on the rail. Mark this distance on the horizontal line beginning at the first mark. Make pilot holes with an awl or 1/8" drill.
4. Install screws in vertical slots and adjust location of drawer. To connect the drawer to the slide member: 1) Close the slide completely. 2) Position the drawer so the rail rests on the drawer member. 3) Push the drawer into the cabinet. At this time, the rail will snap into place securing the rail to the slide.
- 4) Open the drawer to ensure the latch has engaged properly with the drawer member.
5. After adjusting position of drawer, install screws in the round holes, front and rear of slides and rails. For longer slides, install screws in the central holes of both.

32mm System Mounting

Cabinet Member Installation

1. Install an M-6 euro screw through the second hole from the front of the slide and into a 6mm hole located 37mm in from the front of the cabinet. Select a rear mounting hole on one of the 32mm multiples provided and install screws. See Figure 3.

Rail Installation

1. Mark a horizontal line on the drawer side 19.6mm above the slide center line. See Figure 4.
2. Mark a point on this line 44.1mm back from the drawer front. Complete rail installation by following steps 3 through 5 for Conventional Rail Installation.

Ordering Instructions

Complete your slide order for Accuride Model 2632 by specifying the following:

Total Slides Required _____ 100 each C 2632 -12 D
 Slide Finish _____
 Slide Model _____
 Slide Length _____
 Optional Polybag Packaging _____

Sample Handed Rail Order - Bulk Orders Only

(Order one per pair of slides) 100 each 7455-1922-CL
 (Order one per pair of slides) 100 each 7455-1922-CR
 Total Rails Required _____
 Rail Part Number _____

Slide Length	Rail Part Numbers	Rail Length
8" - 10"	7455-0811-CL and 7455-0811-CR	6.50" [165.1mm]
12" - 14"	7455-1215-CL and 7455-1215-CR	10.78" [273.8mm]
16" - 18"	7455-1618-CL and 7455-1618-CR	13.30" [337.8mm]
20" - 22"	7455-1922-CL and 7455-1922-CR	17.08" [433.8mm]

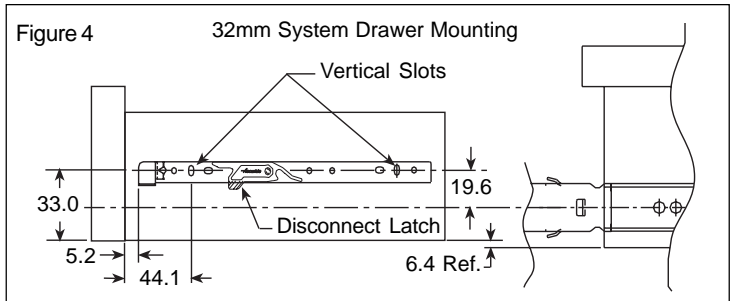
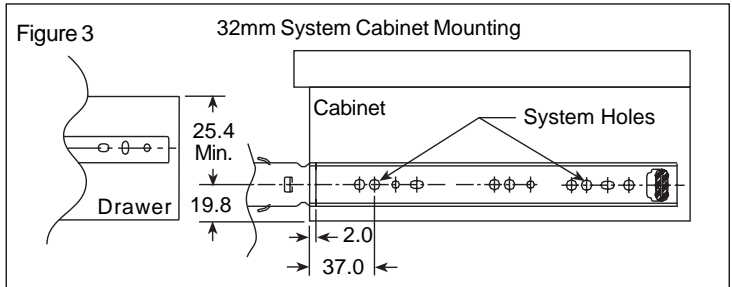
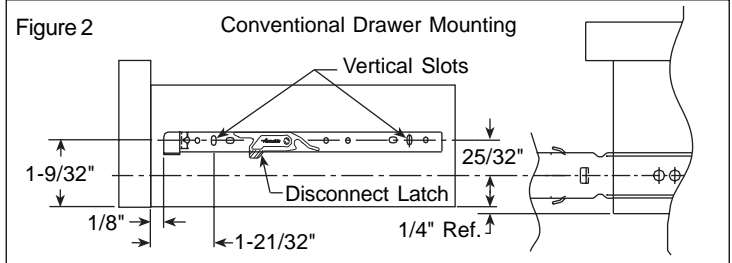
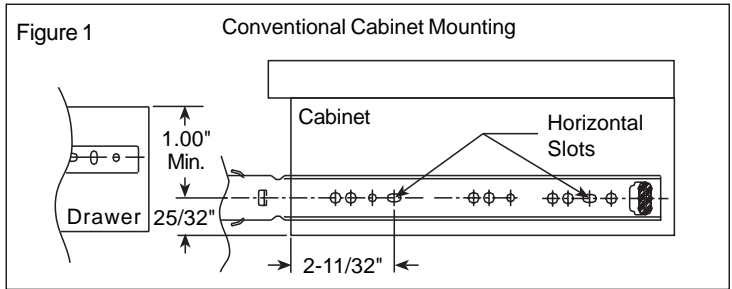

Packaging Information

Bulk (P) Pack: All lengths are packaged 10 pair per box. Handed rails and screws are ordered separately but packaged together.

Distributor (D) Pack: All lengths are packaged 10 pair per box. Polybag includes one pair of slides packaged with handed rails and screws.

X-Press (X) Pack: All lengths are packaged 10 pair per box. Slides, handed rails, and mounting screws packaged together.

Specifications

Slide members and ball retainers: Cold rolled steel
 Ball bearings: Carburized steel

NOTE: Specifications, materials, prices, terms, and delivery are subject to change without notice.

Accuride

ACCURIDE INTERNATIONAL INC.

12311 Shoemaker Avenue
 Santa Fe Springs, CA 90670
 TEL (562) 903-0200
 FAX (562) 903-0208
 www accuride.com

Manufacturing, Engineering, and Sales
 United States • Germany • Japan • Mexico • United Kingdom